



FIRESTOP CENTRE

Authorised New Zealand Distributor
Ph (09) 483 4000 www.firestopcentre.co.nz

AGNI-Sleeve in 1 x 13mm Plasterboard Wall or 118mm Concrete Wall PEX-AL-PEX pipe 32mm FRR -/60/60

Step-by-step installation instructions:

1. Ensure the aperture is free from dust and debris.
2. Cut AGNI-Sleeve to 138mm wide.
3. Measure and cut one revolution of 138mm AGNI-Sleeve to fit the aperture.
4. Pass AGNI-Sleeve through the wall with 10mm extending beyond the plasterboard lining on both sides of the wall.
5. Apply a bead of AGNI-Seal (5mm nominal) between the wall and AGNI-Sleeve.

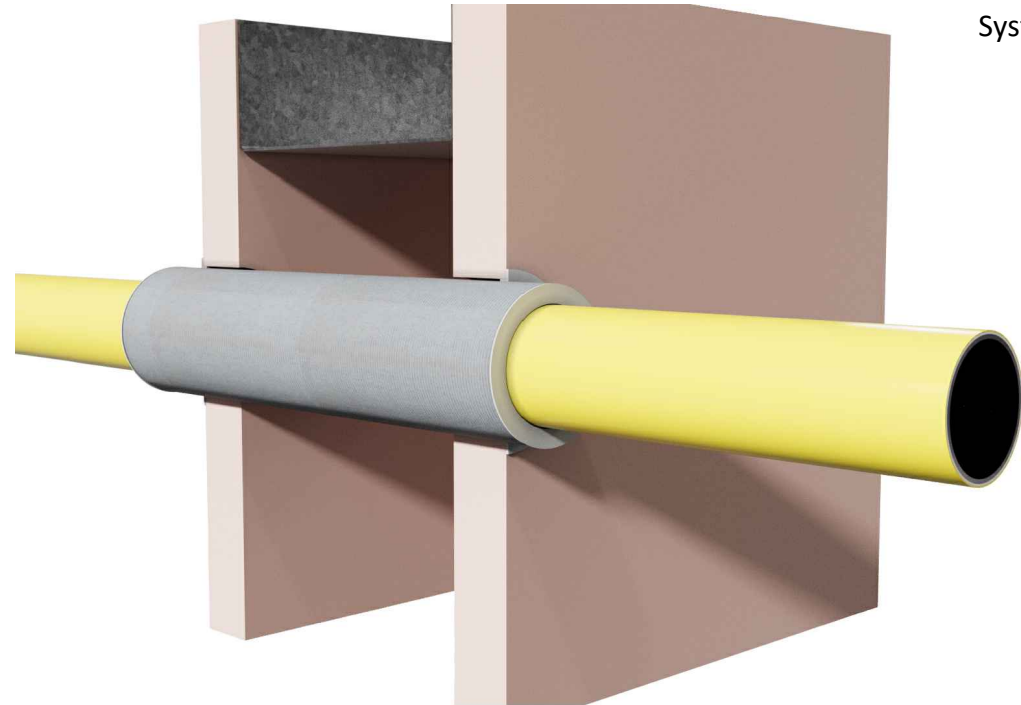

System ID# FC855

Technical Information

Substrate	<ul style="list-style-type: none"> • Min. 92mm steel / timber stud wall with a minimum of one layer of 13mm (or greater) FR plasterboard on each side, with or without insulation. • Min. 118mm concrete wall/masonry wall/block wall
Service range	DN 32mm PEX-AL-PEX pipe
Annular gap	5-9mm
AGNI-Products	AGNI-Sleeve, AGNI-Seal
Protection installation	Both sides of the wall

Compliance Information

Standards	AS1530.4-2014, AS4072.1-2005
FRR/FRL	-/60/60
Reference	PF24082 AP-101



8 Clare St Bayswater
VIC 3153, AUSTRALIA
www.agnitek.com.au

Disclaimer

Agnitek reserves the right to modify product specifications without prior notice due to its ongoing research, development & certification programme. The information in this document is provided in good faith and is intended for guidance purposes only. Any accompanying drawings are solely for illustrative purposes. Since Agnitek cannot oversee installation methods or ensure site conditions, no warranties, expressed or implied, are intended regarding the products' actual performance. We do not accept liability for any loss, damage, or injury from using this information. Please take a look at the test reports displayed on a relevant AGNI-System webpage for all compliance specifics.

Date	20.06.2024
------	------------



FIRESTOP CENTRE

Authorised New Zealand Distributor
Ph (09) 483 4000 www.firestopcentre.co.nz

AGNI-Sleeve in 1 x 13mm Plasterboard Wall or 118mm Concrete Wall PEX-AL-PEX pipe 32mm FRR -/60/60

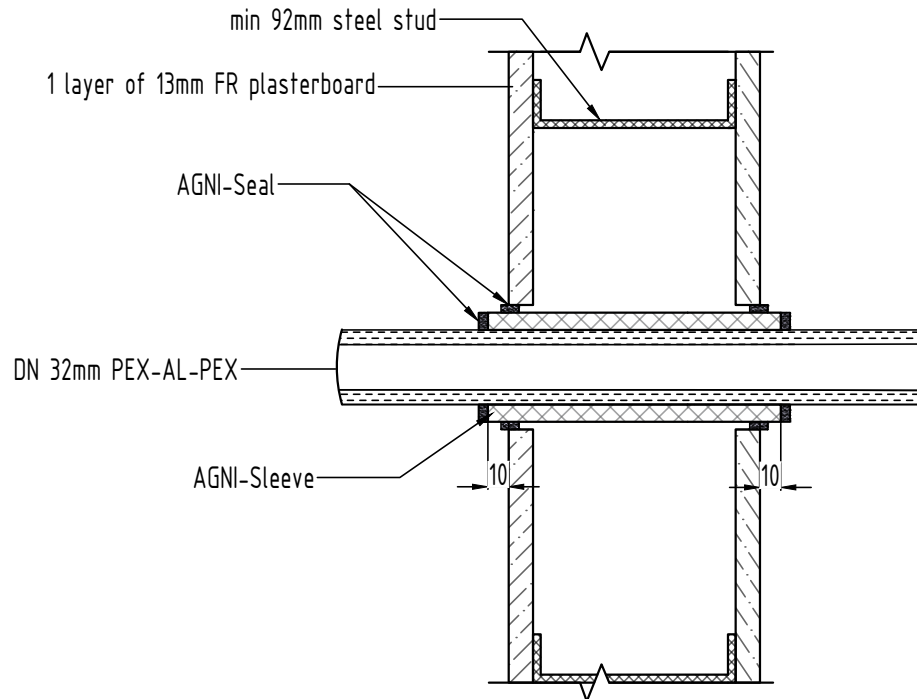

System ID# FC855

Technical Information

Substrate	<ul style="list-style-type: none"> Min. 92mm steel / timber stud wall with a minimum of one layer of 13mm (or greater) FR plasterboard on each side, with or without insulation. Min. 118mm concrete wall/masonry wall/block wall
Service range	DN 32mm PEX-AL-PEX pipe
Annular gap	5-9mm
AGNI-Products	AGNI-Sleeve, AGNI-Seal
Protection installation	Both sides of the wall

Compliance Information

Standards	AS1530.4-2014, AS4072.1-2005
FRR/FRL	-/60/60
Reference	PF24082 AP-101



8 Clare St Bayswater
VIC 3153, AUSTRALIA
www.agnitek.com.au

Disclaimer

Agnitek reserves the right to modify product specifications without prior notice due to its ongoing research, development & certification programme. The information in this document is provided in good faith and is intended for guidance purposes only. Any accompanying drawings are solely for illustrative purposes. Since Agnitek cannot oversee installation methods or ensure site conditions, no warranties, expressed or implied, are intended regarding the products' actual performance. We do not accept liability for any loss, damage, or injury from using this information. Please take a look at the test reports displayed on a relevant AGNI-System webpage for all compliance specifics.

Date	20.06.2024
------	------------